



SPATIAL REASONING PART II

We continue with a discussion of learners' spatial reasoning, and how to support the development of spatial reasoning in learners. The main idea discussed in the previous newsletter (issue 3a) is to help learners to discover properties of shapes by working with and manipulating shapes in different orientations. They then work with shape properties in simple deduction and informal proof. The van Hiele (newsletter 3a) suggested that learners' spatial reasoning becomes increasingly textured as they sequentially master a series of spatial reasoning "levels". Learners cannot work spatially in a higher level before they have conceptually mastered the previous. This is useful information, as it helps teachers to make decisions about how to design lessons to support learner understanding of spatial concepts.



Ari, Louise, Edward and Kerry (Grade 8), doing lesson planning.

Many high school teachers speak of the difficulties they have teaching learners to work with high school geometrical concepts and problems. For example, learners often struggle to prove that a particular quadrilateral is a parallelogram; or

INSIDE THIS ISSUE

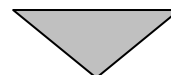

Content	Page
Spatial reasoning Part II	1
What the learners did	3, 5
Discussion of learners' errors	4, 7
Working with shape and area in high school	8
Teaching for spatial reasoning in high school	10
Puzzle	12
Activity sheets	13-23

understand why all rectangles are parallelograms, but all parallelograms are not rectangles. Using the van Hiele's ideas, their confusion is not difficult to understand. In order to prove, for example, that all rectangles are parallelograms, but not all parallelograms are rectangles, learners need to be working at level 2 in spatial reasoning. At this level they know and flexibly use their knowledge of the properties of quadrilaterals. If they are at lower van Hiele levels they will not be able to reason in this way. Strategic thinking at van Hiele level 2 follows after learners have demonstrated competence in working with quadrilaterals at lower van Hiele levels. On the next page is a summary¹ of the van Hiele levels discussed in issue 3a:

¹ This information was obtained from http://images.rbs.org/cognitive/van_hiele.shtml

Level 0	<p style="text-align: center;">"Visualisation" level</p> <ul style="list-style-type: none"> • Sorting, identifying and describing shapes • Seeing different sizes and orientations of the same shape to distinguish between the characteristics of the shape and the features that are not relevant • Building, drawing, making, putting together, taking apart shapes
Level 1	<p style="text-align: center;">"Analysis" level</p> <ul style="list-style-type: none"> • Shifting from simple identification to properties, by using concrete or virtual models to define, measure, observe and change properties • Using models/technology to focus on defining properties, making property lists, and discussing sufficient conditions to define a shape • Doing problem-solving in which properties of shapes are important components • Simple classifying, using properties of shapes
Level 2	<p style="text-align: center;">"Informal deduction" level</p> <ul style="list-style-type: none"> • Doing problem-solving, in which properties of shapes are important components • Using models and property lists, and discussing which properties constitute a necessary and sufficient condition for a specific shape • Using informal deductive language. E.g. "all", "some", "none", "what if", "if-then" • Investigating converse relationships among polygons. E.g. if a quadrilateral is a rectangle, then it must have four right angles : if a quadrilateral has four right angles, then it must also be a rectangle • Using models and drawings as tools to look for generalisations and counter-examples • Making and testing hypotheses • Using properties to define a shape or determine if a given shape is included in a given set

If learners struggle with spatial reasoning, the van Hiele's argue that it is necessary to take learners back to the level at which they can demonstrate geometric reasoning and help them to discover, discuss and share their knowledge of shapes progressively through the higher levels. The van Hiele's argue that teaching at higher reasoning levels when learners' abilities remain at lower levels is a reason why learners are not able to understand conceptually what is being taught.

Before we discuss some spatial reasoning issues in secondary school we present two grade 9 ICAS items which contain both geometric reasoning and use of measurement formulae - specifically area. As usual, we provide a brief analysis of student performance on each, an analysis of how the correct answer may be obtained, and then discuss some of the errors made in each item.

Relevant ASs from LOs 3 and 4 in this issue are:

From LO3: "...Uses geometry of straight lines and triangles to solve problems and to justify relationships in geometric figures"

From LO4: There is no grade 9 assessment standard addressing this concept. The grade 8 AS says:

"Calculates by selecting and using appropriate formulae:

- Area of triangles, rectangles, circles and polygons by decomposition into triangles and rectangles"

(This grade 8 assessment standard also specifies working with perimeter and volume, but we will not address these in this letter)

The grade 9 ASs do not match the items exactly because the ASs in our

NCS are concept-, and not content-based.



Some grade 7 teachers working on lesson plans: Nico, Royston, Euphodia, Lynne and Sakhumzi

What the learners did

The two grade 9 items work with spatial orientation and visualisation, and are as follows:

Gr 9 item 21:

Jill made this shape using three overlapping squares. Each square had sides 12 cm.

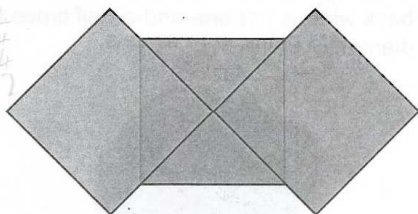

What is the total area, in cm², of the shape?

- (A) 288 (B) 300
(C) 360 (D) 432

33% of learners arrived at the correct answer (C)

32% chose option A
18% chose option D
15% chose option B

To solve the problem correctly learners could have done the following:

1. Calculate the area of one square:

$$\text{Area} = 12 \times 12 = 144\text{cm}^2$$

The whole shape is $2\frac{1}{2}$ squares

$$\therefore 2\frac{1}{2} \times 144 = 360 \text{ cm}^2$$

2. Work out the area of $2\frac{1}{2}$ squares, but do it in more steps:

$$144 + 144 + \frac{144}{2} = 360 \text{ cm}^2$$

3. Calculate the areas of three full squares and then subtract the area of a half square:

$$\begin{aligned} 3 \times 144 &= 432 - \frac{144}{2} \\ &= 432 - 72 \\ &= 360 \text{ cm}^2 \end{aligned}$$

The difficult part of this question is the overlapping parts of the figure. It is important that learners understand that the diagonal of a square divides the area of the square in half. The middle square in this problem has been divided into quarters by its two diagonals, which would have been easy to recognise, if the square had been given on its own:

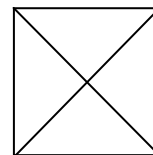

The differently-oriented squares on either side of the middle square, overlapping with the middle square, present a greater challenge to the learners. The diagonals of the middle square are also the sides of the outside squares, but the sides of the middle square are **not** the diagonals of the outside squares; which means that the outside squares do not have their areas divided in half.

Two problems are presented to the learners:

- (1) working out how to subtract the overlapping areas from the total area, and
- (2) which squares to work with when doing these subtractions.

If the learner realises that s/he can solve the problem by ignoring half the area of the middle square; or subtracting half the area of the middle square from the total area, s/he will probably successfully solve the problem. But if the learner wants to work with the overlapping areas of the outside squares, the areas of these overlapping parts are unknown, and the learner can become confused.

Discussion of learner errors

A third of the learners chose incorrect option A, (area = 288 cm^2). This answer may be obtained by calculating the area of the two outside squares only. It is possible that the learners did not know what to do with regions A, B, C and D, and left the middle square out of the calculation.

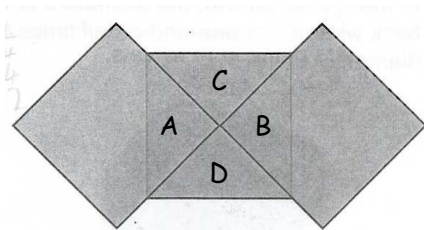

The learners need to realise that regions A and B, must be included only once in the calculation. Also, the whole area is made up by two-and-a-half squares - the two squares being the outside squares, and the half square being areas C and D. The orientation of the figure has made it necessary for the learner to realise s/he must work with the diagonals of the middle square to know that areas C and D are half the area of the full square. Learners need to relate all three

squares to each other because they share areas and properties (the diagonals of the middle square are the sides of the outside squares).

The learners who chose option D calculated the areas of three squares, as though there was no overlap:

$$3 \times 144 = 432 \text{ cm}^2$$

It is likely that they did not realise that in calculating three complete areas, they were including the overlapping areas A and B twice. A possible reason for calculating the areas of three squares is that in the picture, one can see the outlines of all three squares, leading to possible confusion about the fact that although the squares are overlapping, three full squares are still visible. The fact that the test item asks, "what is the total area, in cm^2 of the shape?" can be misleading for English second language learners, because the question asks for "total area", which could be interpreted as the three full squares viewed as though they were not overlapping.

For option B it is possible that the learners found the answer of 300 cm^2 by calculating the area of two squares, as $(2 \times 144 \text{ cm}^2)$, and then adding the 12cm given as the length of a side.

$$(2 \times 144) + 12 = 300 \text{ cm}^2.$$

This kind of procedure is an indication of learners' lack of conceptual understanding of area, which affects the learner's ability to know what to do with the pieces of the middle square that are visible. Seeing two sides of the middle square and knowing they are both 12 is a possible reason why the value of 12, obtained from the written information, was added to the areas of 2 squares:

A difficulty that may exist for learners trying to solve this problem is a lack of clarity as to exactly how many shapes they are seeing, and what these shapes are. The learners have difficulties working with spatial orientation (see issue 3a): they can see the outline of the middle square through the other squares, but may be asking themselves whether they are working with areas of triangles or squares, and how these shapes relate to each other.

Grade 9 item 27:

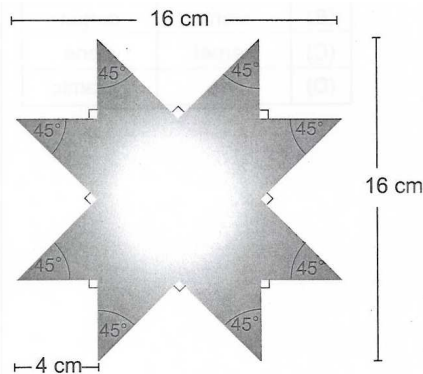

What is the area of this shape?

- (A) 128 cr
- (B) 160 cr.
- (C) 192 cm²
- (D) 224 cm²

25% of learners arrived at the correct answer (A)

33% chose option B

22% chose option D

18% chose option C

There are a few different ways in which the learner could approach this problem correctly:

1. (i) Find the the areas of the 8 triangles, A to H, in the picture below.
- (ii) Find the area of the inside square (I).
- (iii) Add the areas of the inner square and 8 outside triangles

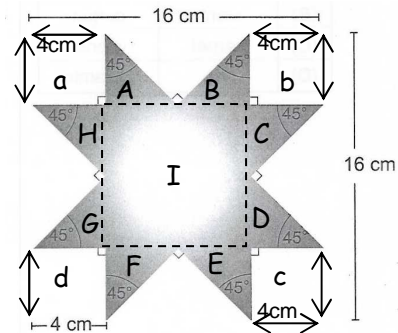

Each triangle A to H is isosceles. The reason is because one angle is 90° and another is 45°. This makes the third angle also 45°. Since the triangles are isosceles, the non-hypotenuse sides are equal in length. The question gives the information that the length of a side of the isosceles triangles is 4cm. Therefore, the other equal side is also 4cm.

For each isosceles triangle, one side of 4cm is a base of the triangle. The other equal side is the perpendicular height, because there is a right angle between the sides.

$$\begin{aligned} \therefore \text{Area each triangle} &= \frac{1}{2} (\text{base}) \times (\text{p.h.}) \\ &= \frac{1}{2} (4 \times 4) \\ &= 8 \text{ cm}^2 \end{aligned}$$

$$\text{Area 8 triangles} = 8 \times 8$$

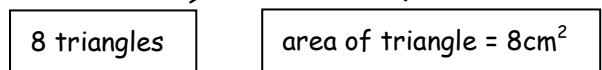

$$\text{Area } \Delta\text{'s} = 64\text{cm}^2$$

To calculate the area of the inner square, I, the length of the side is needed. The length of the sides of the inside square are calculated by

$$\text{Length} = 16 - 4 - 4 = 8\text{cm}$$

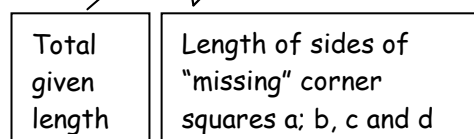

$$\therefore \text{Area of inside square} = 8 \times 8 = 64\text{cm}^2.$$

$$\begin{aligned} \therefore \text{total area} &= \text{Area } \square + \text{Area } \Delta\text{'s} \\ &= 64\text{cm}^2 + 64\text{cm}^2 \\ &= 128\text{cm}^2 \end{aligned}$$

2. While recognizing that the shape is made up of an inside square plus 8 right angled triangles, learners could put together two triangles to form squares that are 4 x 4 in dimension.

So the area is

$$\begin{aligned} &\text{Inside square (of dimension } 8 \times 8) + 4 \\ &\text{squares (of dimension } 4 \times 4) \\ &= (8 \times 8) + 4(4 \times 4) = 64 + 64 = 128 \text{ cm}^2 \end{aligned}$$

3. The third possible method requires the learner to "see", or visualise the whole large square around the star with dimensions 16 x 16 cm, as shown below:

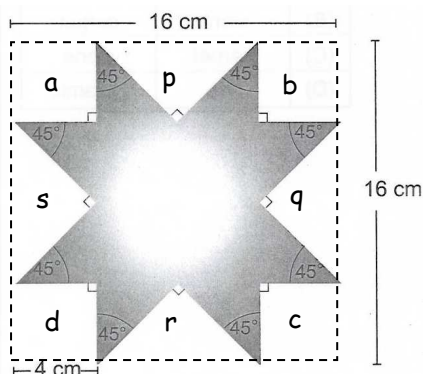

The area of the star shape can be calculated by subtracting the areas of the missing shapes a, b, c and d, and p, q, r and s.

$$\text{Area whole square} = 16 \times 16 = 256 \text{ cm}^2$$

The areas of the four missing corner squares, a, b, c and d, and the four missing 'middle' triangles, p, q, r and s, must be subtracted from the large 16 x 16 square.

Each of the four missing corner squares has dimensions 4 x 4 = 16 cm².

$$\text{For 4 squares, Area} = 4 \times 16 = 64 \text{ cm}^2.$$

The four triangles, p, q, r and s, have lengths of hypotenuse (base) calculated from finding the total length of the big square (16cm) minus the lengths of the two corner squares (2 x 4 cm), which gives a length of 8cm. The perpendicular height of these triangles is the same as the perpendicular height of the triangles making the star, which is 4cm.

For each of these triangles,

$$\begin{aligned} \text{Area} &= \left(\frac{1}{2} \times \text{base} \times \text{ht}\right) \\ &= \left(\frac{1}{2} \times 8 \times 4\right) \\ &= 16 \text{ cm}^2 \end{aligned}$$

For 4 triangles, the total area is

$$\text{Total area} = 4 \times 16 = 64 \text{ cm}^2$$

\therefore the area of the star shape is

$$256 - 64 - 64 = 128 \text{ cm}^2$$

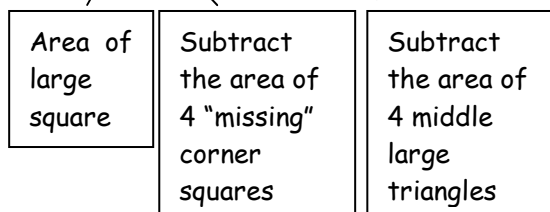

Similar knowledge is required to correctly use all three methods; but the way that the solver "sees" the shapes is different. "Seeing" how the triangles and squares are located in space to form other shapes is part of spatial reasoning. No particular one of these three methods is better than the others - they are just different ways to visualise the problem.

Whichever different ways learners mentally see the figure, they must be able to break down a complex shape into its basic shape components. They must also be able to visualise the shapes that are not there, in order to work out the dimensions of the shapes that are there. In addition, they need to be able to flexibly use area formulae for different geometric shapes.

Discussion of learner errors

A third of the learners chose option B (160cm^2). To get this answer they could have solved the problem as follows:

They calculated the area of the whole 16 by 16 cm square.

$$\text{Area} = 16 \times 16 = 256\text{cm}^2.$$

Then they found the areas of the four missing corner squares:

$$\text{Area} = 4(4 \times 4) = 64\text{cm}^2.$$

Then they found the areas of the missing "middle" triangles, but incorrectly. They may not have seen these triangles as different in size from the other right-angled triangles, and therefore used a base and height of 4cm. Then the area of 4 of these would be:

$$\text{Area of 4 triangles} = 4\left(\frac{1}{2} \times 4 \times 4\right) = 32\text{cm}^2.$$

Therefore, the area of the figure will be the area of the large 16 by 16 square minus the shapes that are missing:

$$\text{Area} = (16 \times 16) - (4 \times 16) - (4 \times 8) = 160\text{cm}^2$$

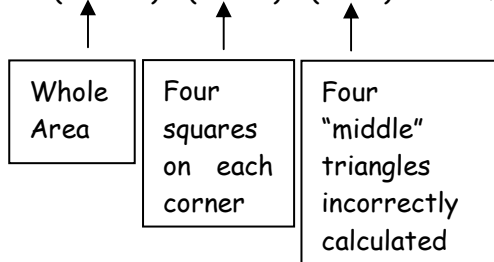

22% of learners chose incorrect answer D (224cm^2). To get this answer the following interesting visualisation may have taken place. It is interesting because it seems logical, until one actually draws what was mentally visualised.

It is possible when trying to visualise the parts of the shape that are missing, that learners did not mentally see the missing

shapes accurately. If they "saw" the missing shapes as drawn below, then they might also have only "seen" the corner triangles a, b, c and d; and not p, q, r and s.

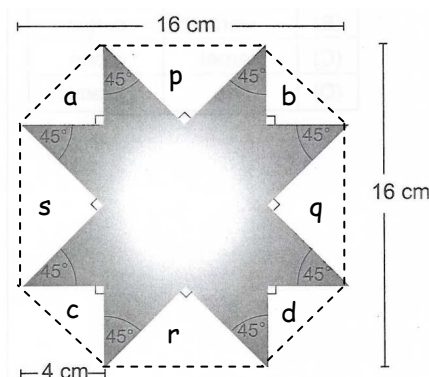

The learners started by calculating the area of the large 16 by 16cm square, which is 256cm^2 . They then calculated the areas of triangles a, b, c and d, and subtracted this total from the area of the large 16 by 16 square. The four "middle" triangles, p, q, r and s, were left out of the calculation i.e. they were not subtracted:

$$\begin{aligned} \text{Area of star shape} &= \text{Area large square} - \text{Area 4 corner } \Delta\text{'s} \\ &= 256 - 4 \times \left(\frac{1}{2} \text{ base} \times \text{h}\right) \\ &= 256 - 4\left(\frac{1}{2} \times 4 \times 4\right) \\ &= 224\text{cm}^2 \end{aligned}$$

18% of learners chose option C. To get option C, learners may have visualised the same picture as the one drawn above for option D, but not left out any of the triangles. The eight triangles may all have been incorrectly visualised as identical. They used the correct formula to calculate the areas of triangles a, b, c and d, but not for triangles p, q, r and s. The result is the calculation:

$$\begin{aligned} \text{Area} &= \text{Area large square} - \text{area 8 triangles} \\ &= 256 - 8 \times \left(\frac{1}{2} \text{ base} \times \text{h}\right) \\ &= 256 - 8\left(\frac{1}{2} \times 4 \times 4\right) \\ &= 256 - 64 \\ &= 192\text{cm}^2 \end{aligned}$$



Louise (team leader) and Fatima (grade 6)

HANDLING LEARNERS' PROBLEMS IN SPATIAL REASONING

Spatial reasoning in primary school is largely concerned with van Hiele levels 0 to 2. (Refer to issue 3a for an in depth discussion of these levels of spatial reasoning, because it is equally applicable to high school teachers). We list the main spatial reasoning components in the next section. Unusual spatial orientation is one of the factors leading to learners' difficulties in solving spatial problems. Learners need to recognise that a particular shape belongs to a certain set of shapes, even if it is oriented differently. For example, a typical misconception is observed when learners see a square rotated so that it sits on a vertex instead of a side, and do not classify it as a square, but as a diamond. In the drawing below they need to be able to see the difference between squares A and B, rhombus C (or diamond, in the language of a level 0 learner), and kite D (or diamond in the language of the level 0 learner), on the merits of their properties, not because they are oriented differently.

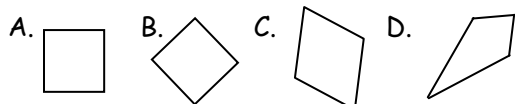

The grade 9 items discussed above are oriented unusually, but the components of the complex shape in each question are basic shapes - squares and triangles - which learners have been working with since grade R. What, then, makes these problems so difficult for learners to solve?

Working with shape and area in high school

The difficulty with solving grade 9 spatial problems is that they require more knowledge about the properties of shapes, such as diagonals, right angles, comparative side lengths and perpendicular heights; and are made up of a greater variety of shapes than in primary school. For more complex items, learners have to combine their knowledge of a greater variety of geometric properties with unusually-oriented shapes and with the measurement concepts of perimeter and area.

The grade 5 items in issue 3a represented problems where the square shapes are combined in various ways to produce a complex shape, which must then be worked with. In the grade 9 items learners need to identify the individual shapes making up the complex picture. In addition, they need to mentally alter the pictures. In item 21 they need to picture the whole middle square, but also realise that some of the square is not included in the area calculation and "remove" it from their mental picture and their calculations. In item 27 they may need to picture the shapes that are not there (the "missing" corners being squares, not triangles), so that they can devise strategies to find the area of the unusual shape.

With respect to the van Hiele levels of geometric reasoning, learners are required to mentally visualise a complete figure that is not provided, or change, add to or take away from a figure that is provided. The grade 9 items in this newsletter require thinking at Level 3. The van Hiele levels 0 to 2 are described on page 2. Summarised they are, level 0 (visualisation); level 1 (analysis); and level 2 (informal deduction)

"Formal Deduction" at level 3 requires learners to use what they know is always true (for example, all the properties of quadrilaterals, and how they relate to each other), to reason through proving cases that they do not know are always true. In these grade 9 ICAS items learners have to use properties of squares and triangles to solve the problems. These include how diagonals affect the area of a square, how to visualise perpendicular heights of triangles from different vertices, depending on the orientations of the triangle and the type of triangle drawn, and how to work with positive and negative space in solving spatial problems.

Working with positive and negative space is an important aspect of visualisation and should be incorporated into the activities learners do. Item 27 requires learners to understand and accurately use positive and negative space.

The positive space is the actual star shape. The negative space is the part of the picture that is missing, and consists of a square at each corner and 4 middle right-angled triangles, shown by the dotted line around the shape below. Learners are probably aware that the big shape is the square of 16 by 16 cm, because that information is clear on the diagram.

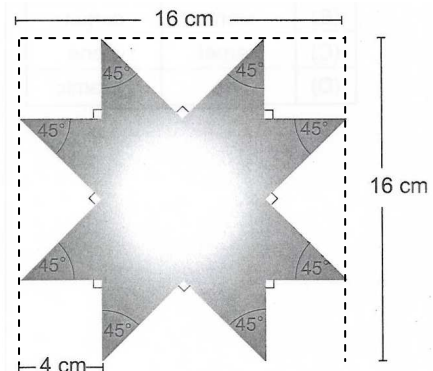

However, when they want to start subtracting the areas of the negative spaces (the missing corners and middle pieces), they may do it incorrectly - especially if they only imagine the negative spaces and do not physically draw them onto the picture. If this is the case, then they may work with negative spaces that look like this (we showed how this produced one of the distractors):

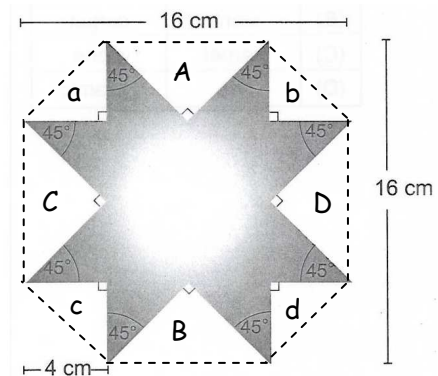

Before facing the difficulty of having to choose which formulae to use, learners face the problem of having to visualise the shapes they can see and those they cannot. Understanding the geometric relationships in the figure allows them to strategically decide that they must find the area of the full square and subtract the area of the negative space (the "missing" corner squares and middle triangles) to calculate the positive space (the shaded area).

In issue 3a we provided an activity sheet that required complex shapes to be broken down into their individual component shapes; with the absence of any calculations. Remember that there may be many different ways to do this, and learners should be encouraged to explain why they broke down a shape in one particular way, compared to how other learners might have done it. In this newsletter an activity sheet is provided where learners need to not only break down a complex shape, but also calculate the area of the complex shape. It is a good exercise because they will work with both shape properties and areas. i.e. it combines LO3 with LO4.



Mandla, Shadrack and Mogorosi (grade 9), discussing lesson plans

Teaching for spatial reasoning in high school

Teaching spatial reasoning can be more effective if the teacher is aware of learners' current levels of spatial reasoning, and teaches them through those levels into new levels. Issue 3a dealt with teaching new spatial concepts to learners and we summarise the points made for you here, because they are equally relevant to learning new concepts in high school.

- When learners meet a new concept they begin to work at level 0, regardless of their age or maturity.

- The learners in your class will most likely be at a few different levels at any point.
- Teachers need to begin their teaching at the level of the learners, not at the level where teachers think the learners should be.
- Advancement to a new van Hiele level can take place when learners are competent in the previous level.
- In the first stage of teaching a new concept in spatial reasoning, teachers and learners make and discuss observations about the objects of interest. Learners should be encouraged to explain their arguments concisely using correct language.
- The next stage of teaching new material involves materials carefully sequenced by the teacher, which gradually reveal the properties of figures that are characteristic at the particular level.
- Subsequently learners begin to have a grasp of the relationships between shapes. The teacher tasks the learners to express and exchange their emerging views about what they are discovering.

We explained that the primary school works with fundamental spatial concepts, and therefore learners do not usually work with complex spatial problems that are solved using multiple steps. This kind of work should begin in primary school, so that learners start to think through problems that are not straightforward. From grade 7 onwards problems should become even more complex. At level 3 learners need to go beyond only identifying characteristics of shapes and learn to construct formal deductive proofs using axioms and definitions. For example, grade 9 learners will use geometric definitions and deductive reasoning to prove a pair of lines parallel. In grade 11 knowledge of properties and

relationships of quadrilaterals is used in conjunction with that of circles to prove that the opposite angles of a cyclic quadrilateral add up to 180° .

The following question is an example of where learners at a grade 9 level have to use deductive reasoning:

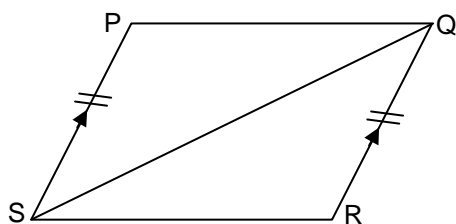

In quadrilateral PQRS, $PS = QR$
and $PS \parallel QR$.

Prove that:

- (i) $\triangle PSQ \cong \triangle RSQ$
- (ii) $PQ \parallel SR$
- (iii) What kind of quadrilateral is PQRS?
Give a reason for your answer

To help learners to work at level 3 of spatial reasoning teachers' questions should make explicit the implicit relationships that learners have been exposed to. In the above task, questions asked may include: Where does the drawing provide you with information you can use?; What are the different ways we can use to prove triangles congruent?; What do we know about the two triangles that can help us to prove them congruent?; or Why is it helpful that those two triangles share a common side?; What do we need to know in order to prove lines are parallel?; Show me how you can prove that those two sides are parallel.

After relationships between shape properties have become explicit learners can synthesise new information from the knowledge they have gained. The teacher may help in this process by summarising relationships and helping learners through questioning to realise how their knowledge

fits with other knowledge in order to make logical deductions.

SOME LEARNER ACTIVITIES

Two van Hiele activities have been provided on the following pages. Continuing from issue 3a, the fifth activity sheet focuses on working with angles. Although we have not talked about angles in this newsletter, spatial reasoning requires application of all properties of figures, which includes their angles. The sixth activity sheet works with discovering principles of area and perimeter using the rectangular mosaic pattern referred to by van Hiele. The seventh activity sheet is aimed at giving learners more opportunity to work with linking LOs 3 and 4 through finding areas of complex shapes.

Using the Activity Sheets

As with issue 3a, the activity sheets cannot be copied and given directly to learners, as they include instructions to teachers throughout. You need to copy the questions and activities with the learner instructions onto new learner-specific activity sheets.



Million (team leader) and Alfred (subject adviser) (grade 6) discussing lesson planning with visuals

PUZZLE

Solution to puzzle from volume 2 issue 2

This question was an ICAS test question.
Can you do it?

The diagram shows four identical overlapping parallelograms.

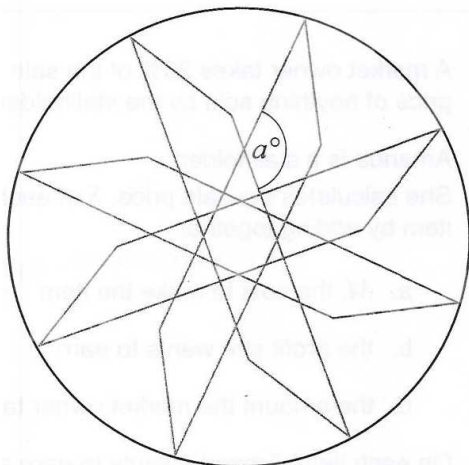

The vertices of the parallelograms touch the circle at evenly spaced points.

What is the value of a ?

8	1	6
3	5	7
4	9	2

There is no elegant solution for this, but logic can help you to work out a solution. The biggest three numbers should each be in a different column, diagonal and row. (You can see that 9, 8 and 7 follow this pattern. If they are together on any column, row or diagonal, you will get a total of more than 15 at least once). Similarly, the smallest three numbers, 1, 2 and 3 should all be on a different column, diagonal and row. It also makes sense that the smallest number is more likely to go with the biggest number. This is why 1 is in the same column as 9; 2 is in the same diagonal as 8; and 3 is in the same row as 7. Put 5 in the middle, as it is the middle number; and in this respect is halfway between a "big" number (9) and a "small" number (1). You are then left with 4 and 6 to place; which can be done more by trial and error.



SHAPES ACTIVITY SHEET 5:

Working with Angles

Levels 1, 2

We are working with the mosaic pattern referred to in issue 3a. It is provided again below. The pieces of the mosaic have 5 different angles. The concept of “angle” is difficult for many learners to understand, as you know and this activity will be beneficial to many learners in different grades.

If you want to do this activity with high school learners, we strongly advise you to do the activities in issue 3a first, to allow your learners to become familiar with the mosaic. The activities may appear to be appropriate for primary school children only, but even you as the teacher should do the activities with the mosaic before you give them to your learners, as you will probably be surprised to make a few new discoveries yourself when working with these shapes.

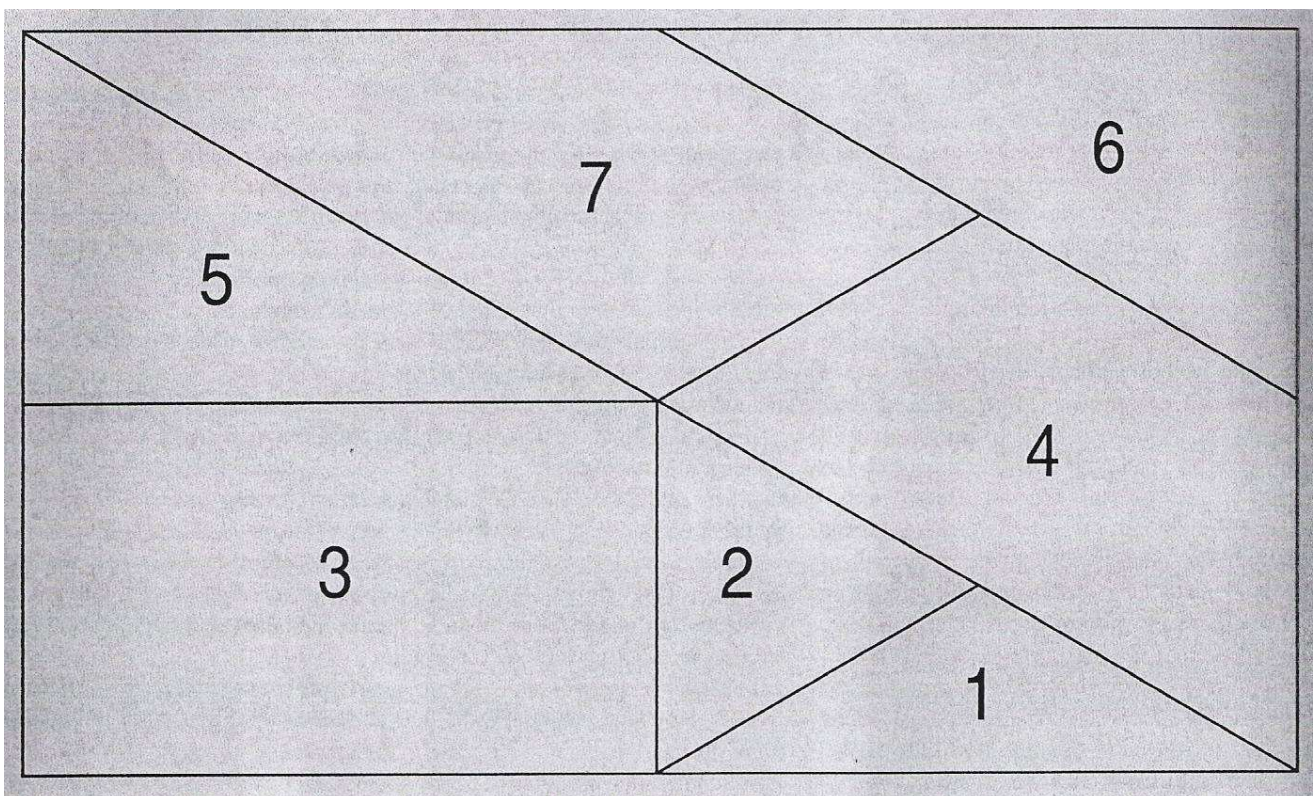

1. The first activity is a “game” of recognition.

Learners are to work in pairs. They have one set of cut out cardboard mosaic shapes between them. One learner closes her eyes and is given a shape by the other.

- 1.1. The learner with her eyes closed has to verbally describe the shape to the other learner, by running her fingers along the edges of the shape and over the vertices.
- 1.2. The learner with her eyes closed can try to determine how many sides the shape has and name it as a triangle or a quadrilateral.
- 1.3. The learner with her eyes closed can be given two shapes to describe before they swop roles. She can compare the shapes in terms of their edges and their vertices. Descriptions should be as detailed as possible: ‘this vertex is “pointier” than that one’; or ‘this angle is smaller than this one’, ‘these two sides slope away from each other and these two sides slope towards each other’, or ‘These two sides are parallel’.

2. The second activity works specifically with comparing angles of shapes.

Mosaic pieces 5 and 6 each have a right angle. It is useful to use the right angles as a reference, with which learners can compare the angles of the other shapes.

- 2.1. Allow learners time to experiment with the angles of all the mosaic shapes. They can place one angle on top of another. For example, place the sharpest angle from piece 7 on top of one of the angles of piece 2. They can relate their findings to each other and write them down as they find out new results. When the smallest angle of piece 7 is on top of piece 2, learners can see that the angle is smaller (because the vertex is sharper). But if one of the angles of piece 2 is placed on top of the right angle of piece 5, or onto the obtuse angle of piece 7, then it is smaller than the latter two angles. Many comparisons may be discovered in this way.
 - 2.2. Ask learners to compare all the other angles from all of the other pieces to the right angle on piece 5 or 6. In this way they can informally discover angles that are greater than and smaller than 90° , and can be introduced to the terms “acute”, “obtuse”, “right angle” and “perpendicular”.
 - 2.3. Learners can be asked to trace around the shapes into their books and number the angles in order of smallest to biggest, or vice versa.
3. All vertices of all mosaic pieces may be placed onto the triangle grid used in the activity sheets in issue 3a (drawn again below for you), and compared with the angles of an equilateral triangle. They can also note that the size of the figure does not determine angle size.

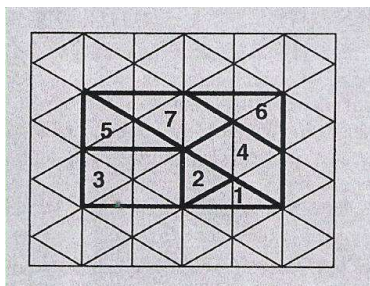

These activities are very useful because they give learners a great deal of experience working with the shape and sizes of angles, without ever having formally measured angle sizes with a protractor. Do not be in a hurry to introduce the protractor to them – let learners understand how an angle is visualized, and how it may be oriented (it does not have to have one of its rays positioned horizontally).

SHAPES ACTIVITY SHEET 6:

Introducing area, perimeter using the mosaic

Level 1, 2

1. Learners can experiment with concepts of area using the mosaic. The experiments deal with finding out how some pieces take up more space than others and how shapes fit on top of other shapes. It is best to work with the triangle grid for this exercise, as all the triangles on the grid are identical, and the number of triangles taking up the same amount of space on the grid as another shape can be counted.
 - 1.1. Put piece 7 onto the grid. How many triangles does it cover? (Don't forget to count the half-triangles).
 - 1.2. Now put piece 6 onto the grid next to piece 7 How many triangles does piece 6 cover?
 - 1.3. Compare pieces 6 and 7. Which is bigger? Why can you say that this piece is bigger?
 - 1.4. Now compare all the pieces of the mosaic with each other. For each piece, how many triangles does it cover? Fill in the table below, ordering the pieces from smallest to biggest from your experiments with putting them onto the grid.

	Number of triangles covered	Piece number
 <p>Smallest</p> <p>Biggest</p>		

- 1.5. Try to write down as many relationships between the pieces as you can. For example, piece 5 is half the size of piece 3. Now describe some other relationships.

SHAPES ACTIVITY SHEET 7

Level 3

(grades 7, 8 and 9)

A. Below are complex shapes made up of basic shapes. For each complex shape,

- a) Break down each complex shape by drawing dotted lines onto each of the complex shapes below. Name the shapes that make up the complex shape. A few of the shapes can be broken down in more than one way. Try to break them down in more than one way, if possible.
- b) Draw separately each shape you named in (a), and draw its dimensions (lengths of sides, heights, etc.)
- c) Calculate the area of each complex shape

1.

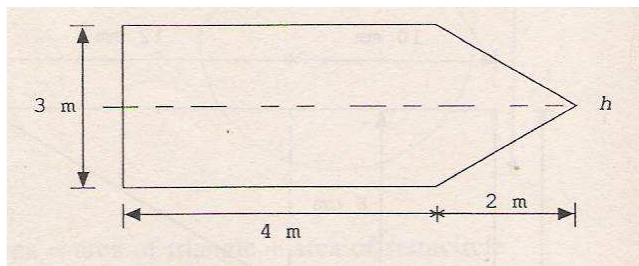

2.

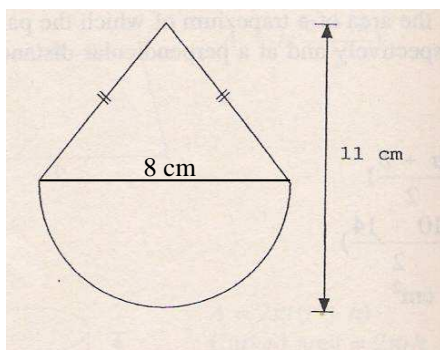

3.

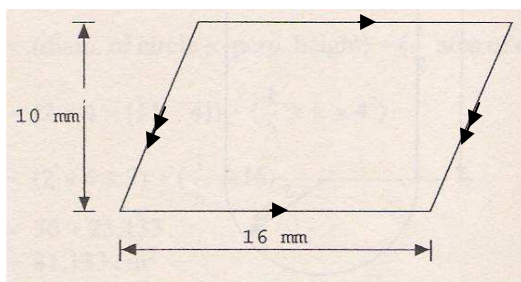

4.

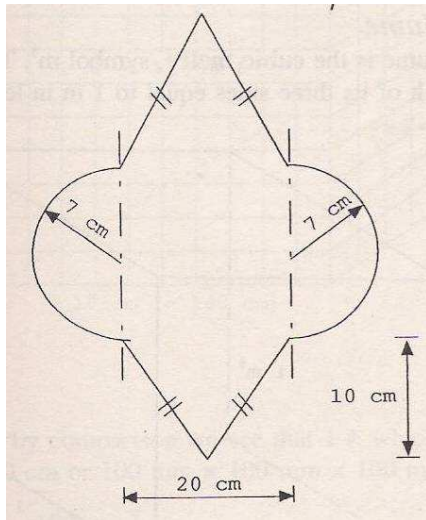

5. Do this one in four **different** ways

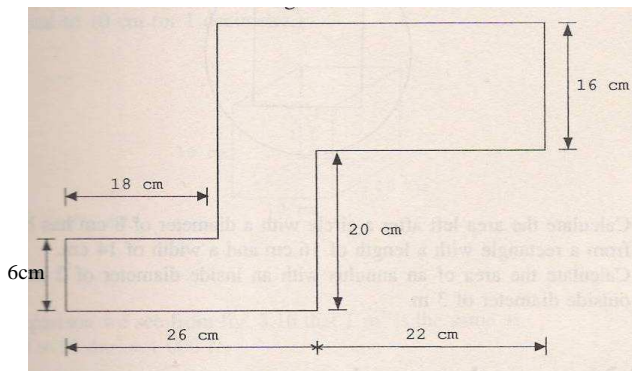

6.

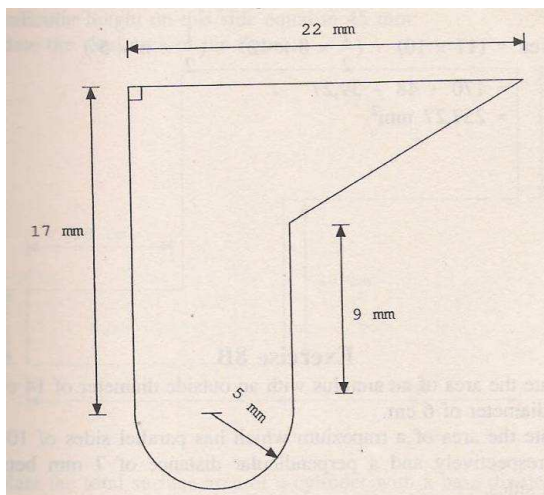

- B. a) Name the positive (shaded area) and negative shapes (the unshaded "missing" shape) in the figures below
- b) Calculate the area of the shaded region in each figure below

7.

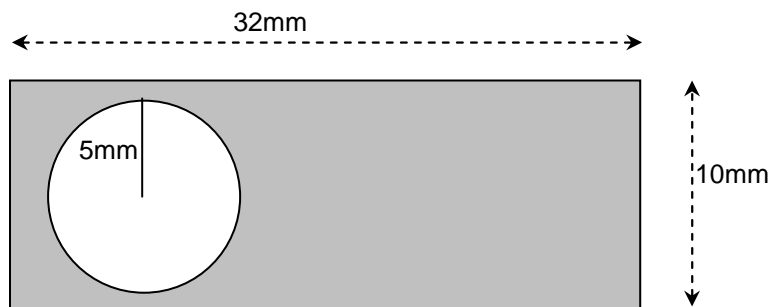

8.

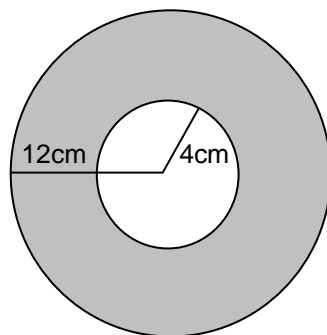

9. AC is the diameter of the circle

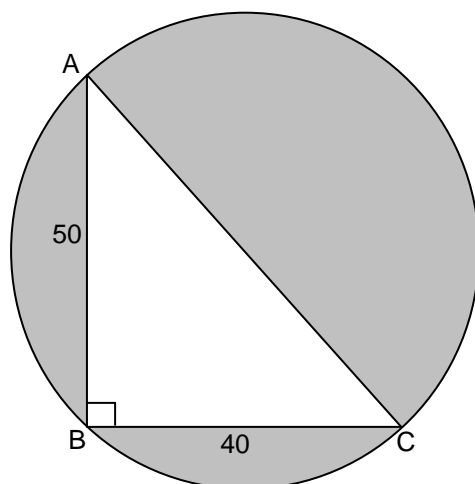

10. Calculate the areas of the grade 9 items discussed in this Newsletter

Solutions for Activity sheets 5 and 6



Activity Sheet 5:

2.



Angles in mosaic pieces	
Mosaic piece	Types of angles
1	Acute, Acute, Obtuse
2	Acute, Acute, Acute
3	Right angle, Right angle, Right angle, Right angle
4	Acute, Acute, Obtuse, Obtuse
5	Right angle, Acute, Acute
6	Acute, Acute, Obtuse, Obtuse
7	Right angle, Acute, Acute

Activity Sheet 6:

1.

	Number of triangles covered	Piece number
Smallest   Biggest	1 whole triangle	1
	1 whole triangle	2
	2 whole triangles	4
	2 whole triangles	5
	2 whole triangles	6
	3 whole triangles	7
	4 whole triangles	3

3.

	Total number of triangle sides around piece	Piece number
Smallest   Biggest	3	2
	2 sides and 2 perpendicular heights	1
	2 sides and 4 perpendicular heights	3
	4 sides	4
	3 sides and 2 perpendicular heights	5
	3 sides and 2 perpendicular heights	6
	4 sides and 2 perpendicular heights	7

4.

	Area (write the piece number)	Perimeter (write the piece number)
↑ Biggest ↓ Smallest	1	2
	2	1
	4	3
	5	4
	6	5
	7	6
	3	7

Solutions for Activity Sheet 7

1. Area $\square = 3 \times 4 = 12\text{m}^2$
 Area $\triangle = \frac{1}{2}(3 \times 2) = 3\text{m}^2$
 Total Area = 15m^2

3. Divide the shape into two identical triangles: the \perp height of each is 10, but it is external to the triangle in the second picture below.

\perp height = 10

Area two \triangle 's = $2[\frac{1}{2}(\text{base} \times \text{height})]$
 $= 2[\frac{1}{2}(16)(10)]$
 $= 160\text{mm}^2$



5. Broken up into the following parts:

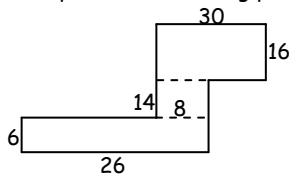

Area = $(6 \times 26) + (8 \times 24) + (16 \times 30)$
 $= 748\text{cm}^2$

Also can be broken down as

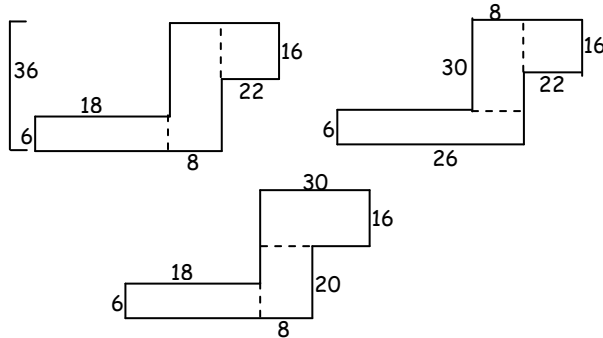

7. Area $\square = 10 \times 32 = 320\text{mm}^2$
 Area $\bigcirc = (\pi \times 5^2)$
 $\cong 78,54\text{mm}^2$
 Area shape $\cong 320 - 78,54 \cong 241,46\text{mm}^2$

8. Area shape = Area big circle - Area small circle
 $= (\pi \times 12^2) - (\pi \times 4^2)$
 $\cong 402,12\text{cm}^2$

10. Answers in Newsletter text

2. Diameter semi- $\bigcirc = 8\text{cm} \therefore r = 4\text{cm}$
 \therefore Area semi- $\bigcirc = \frac{1}{2}(\pi r^2)$
 $= \frac{1}{2} \times \pi \times 4^2$
 $\cong 25,13\text{cm}^2$

\perp height $\triangle = 11 - 4 = 7\text{cm}$
 Area $\triangle = \frac{1}{2}(8)(4)$
 $= 16\text{cm}^2$

\therefore total Area $\cong 25,13\text{cm}^2 + 16\text{cm}^2$
 $\cong 41,13\text{cm}^2$

4. Area two semi- \bigcirc 's = $2(\pi r^2)$
 $= 2\pi(7^2)$
 $\cong 307,88\text{mm}^2$

Area two \triangle 's = $2[\frac{1}{2}(\text{base} \times \text{height})]$
 $= 2[\frac{1}{2}(20)(10)]$
 $= 200\text{mm}^2$

\therefore total Area $\cong 507,88\text{cm}^2$

6. total Area = Area semi- \bigcirc + Area \square + Area \triangle
 $= \frac{1}{2}(\pi r^2) + (l \times b) + (\frac{1}{2}(\text{base} \times \perp \text{ht}))$
 $= \frac{1}{2}(\pi \times 5^2) + (10 \times 17) + (\frac{1}{2}(12 \times 8))$
 $\cong 257,27\text{mm}^2$

9. $AC^2 = 50^2 + 40^2$

$AC = 64,03$

$\therefore r \cong 32,02$

Area $\bigcirc = (\pi \times 32.02^2)$
 $\cong 3220,01$

Area $\triangle = \frac{1}{2}(\text{base} \times \perp \text{ht})$
 $= \frac{1}{2}(40 \times 50)$
 $= 1000$

Area shape $\cong 3220,01 - 1000 \cong 2220,01$